

PO-MANU0-0609XX  
 March 2008  
 Rev D2

Serial # \_\_\_\_\_



# “CENTREX 1000 Family” OWNER’S MANUAL

Electrical Specifications	1000	1000 NE	1000 AC/DC
Maximum Amps	2.4	NA	2.4/NA
Fan Watts (Required or Optional Hook-up)	35 req.	1.4 opt.	35 req./ 1.4 opt.
Heater Watts (When on)	260	NA	260
Average Power Use In Watts (Heater on 1/2 time)	150	NA	150



**CENTREX 1000**



**CENTREX 1000 AC/DC**



**CENTREX 1000 NE**



Certified to NSF/ANSI Standard 41

Standard 41  
 Certified for liquid  
 containment, odors, and solid  
 end products in cottage use

**RATED CAPACITY**  
**Weekend & Vacation Use Only**  
**(Cottage Use)**

**Electric Use:**

4 Adults

**Non-Electric Use:**

5 Adults



Product Info: (905) 332-1314  
 E-mail: [compost@sun-mar.com](mailto:compost@sun-mar.com)

Fax: (905) 332-1315

Tech. Service: (905) 332-1314  
<http://www.sun-mar.com>

600 Main St.  
 Tonawanda, N.Y.  
 14150-0888 U.S.A.

5370 South Service Rd.  
 Burlington, ON  
 L7L 5L1 CANADA



# OWNER'S MANUAL

## CONTENTS

<b>Introduction</b>	<b>How your composting toilet Works</b> How Composting Works 2 The Composting Chamber 2 Compost Finishing Drawer 2 Evaporation Chamber 3 Winter Use 3 CENTREX 1000 Family Part Numbers Wiring Diagram 4 CENTREX 1000 Family Explosion Drawing 5	<b>2-5</b>		
<b>Chapter 1</b>	<b>Inspection</b> Check for Damage 6 Check for Parts and Functionality 6 Placement of unit 6	<b>6</b>		
<b>Chapter 2</b>	<b>Installation</b> CENTREX 1000 Rough in Dimensions 7 Included in your kit 8 Installing the 1 Pint(500ml) Low-Flush Toilet 8 Installation Considerations for the Waste Pipe 9 The 3" (75mm) Waste Inlet Drain Installation 9 Handling Effluent 10 Vent Pipe Location 10 Adjusting the Fan Gate 10 Vent Pipe Installation 10 Leading the Vent through the roof The Diffusor 11 Electrical Considerations 11 12 Volt Fan Installation 12	<b>7-12</b>		
<b>Chapter 3</b>	<b>Start Up and Use</b> Initial System Start Up 13	<b>13-15</b>		
				Annual Start Up 14 Periodic Check Up 14 Ongoing Maintenance 15
			<b>Chapter 4</b>	<b>Compost Troubleshooting</b> Requirements of an Aerobic Compost 15 Compost Too Wet 16 Compost Too Dry 16 Waste not Breaking Down 16 Lumps 17 Drum Too Full 17 Flies 18
			<b>Chapter 5</b>	<b>Mechanical Troubleshooting</b> Urine Odor In Washroom 19 Occasional Urine Odor Outside 20 Sewage Odor when drum turns 20 Fan Noisy 20 Fan Not Working 21 Liquid Buildup/ Lack of Evaporation 21 Overflowing Liquid 21 Heating System Not Working 22 Liquid In Finishing Drawer 23 Drum Will Not Stay Vertical 23 Drum Will Not Turn 23 Drum Door Not Opening/ Closing 24 Waste Not Exiting Waste Pipe 24
				<b>Composting Accessories</b> <b>25</b>
				<b>Warranty Information</b> <b>26</b>
				<b>Basic Maintenance</b> <b>27</b>

## Introduction

### HOW YOUR COMPOSTING TOILET WORKS

*The key to the success of the "CENTREX 1000 Family" lies in its three chamber design. Each of the three chambers; composting, compost finishing, and evaporation have their own independent environments for optimum efficiency.*

Composting is a natural recycling process where human waste and toilet paper are broken down by microbes into minerals and converted back to earth. Heat, oxygen, organic material and moisture are needed to transform this waste into good fertilizing soil, perfect for your flower beds.

Oxygen is provided by the ventilation system, and by tumbling of the composting drum. Additional organic material is introduced by adding "Compost Sure" (or peat moss mix). The waste entering the toilet is approximately 90% water content. Any excess liquid which is not absorbed will collect on the floor of the unit (evaporation chamber) where it may be evaporated into water vapor and carried back to the atmosphere through the venting system. The remaining waste material is transformed into an inoffensive earth-like substance.

#### **The Composting Chamber**

The composting chamber is in the form of a Bio-drum which holds the natural compost heat, provides the necessary mass to maintain a good compost, and is rotated by turning the handle to achieve perfect mixing and aeration.

There are two sets of doors on the Bio-drum, the input and output doors. During mixing, both doors in the drum closed. When the drum returns to the top dead centre position ready to receive more

waste, the input door remains open.

Compost is extracted from the drum periodically, by releasing (pulling) the white drum locker button, and turning the handle counter-clockwise so that the drum rotates clockwise. When this is done, the output door stays open, and compost falls into the second chamber; the compost finishing drawer.

To ensure that the compost remains moist, but does not get too wet (between 40 and 60% moisture content is ideal), any excess liquid which the compost cannot absorb drains through a screen in the rear of the drum directly onto an evaporating tray beneath the screen, and from there, overflows into the evaporating chamber. The evaporating tray can be removed periodically to remove peat moss debris that has accumulated.

#### **Compost Finishing Drawer**

The compost finishing drawer is at the extreme right of the unit below the composting drum, and just above the evaporating chamber. Compost from the drum is isolated in the drawer where it is allowed to 'finish' composting. For seasonally used units, several drawers of finished compost are normally removed at the beginning of the season. Otherwise some composted material can be extracted into the drawer and left there for 3-4 weeks until it is time to remove more compost from the drum.

## WARRANTY

SUN-MAR Corp. warrants the original purchaser that this toilet is free from defects in material and workmanship under normal house or cottage use. SUN-MAR Corp. will furnish new parts for any part that fails within three years provided that our inspection shows that such failure is due to defective material or workmanship. Any part supplied by us to replace another part is warranted for the balance of the original warranty period.

This warranty does not cover:

1. Damage resulting from neglect, abuse, accident or alteration; or damage caused by fire, flood, acts of God or any other casualty.
2. Parts and accessories not sold or manufactured by SUN-MAR Corp. or any damage resulting from the use of such items.
3. Damage or failure resulting from failure of the purchaser to follow normal operating procedure outlined in the Owner's Manual or in any other printed instructions.
4. Labor and services charges incurred in the removal and replacement of any parts found defective under the terms of this warranty.
5. All returns to the factory must be made freight prepaid. All shipments from the factory are made F.O.B. the factory.

This warranty is in lieu of all other warranties expressed or implied, and no person is authorized to enlarge our warranty responsibility, which is limited to the terms of this certificate. The Company reserves the right to change, improve or modify its products without obligation to install these improvements on equipment previously manufactured.

## Basic Maintenance Instructions

Sealand toilet and 'Centrex Family' Central Units

The toilet is porcelain and should be cleaned with hot water or bio-degradable products to avoid damage to the compost. If required 'Compost Quick' or Baking Soda can be used diluted in hot water.

### Three times a week / weekly maintenance:

Turn drum to reveal waste inlet hole through access port and add compost mix at the rate of @ 1 cupful (250ml) per person per day.

Rotate handle clockwise to mix contents of Bio-drum and give 6 complete revolutions of the drum - (36-40 rotations of the handle). Ensure that the drum door opening is in the vertical position at the end after hearing the 'click' of the catch.

Spray 'Compost Quick' into the drum before and after mixing - also once a week in base of unit and finishing tray.

### Check compost volume and condition in Bio-drum and:

If the waste in the Bio-drum is too wet add wood shavings to improve aeration.

If composting is too slow add one scoop of Microbe Mix every second week, and ensure that the drum is not more than 1/2 full. If it is, follow the instructions for the emptying cycle.

### Monthly maintenance and emptying cycle:

Rake out evaporation chamber with rake provided. For units with one (Centrex 1000, 2000, & 3000 units) The black evaporating tray should be removed, solid matter tipped into the finishing tray and then replaced beneath the drum screen.

Empty out the collection chamber ready to receive fresh material.

**Attention:** The composting unit must remain plugged in to an electrical outlet continuously to function odorlessly. The AC/DC units should have both fans running while used in electric mode to prevent recirculation between vent stacks. If you will be away from the residence where the composting unit is installed for longer than three days, the power may be disconnected while the composting unit lays dormant.

## Evaporating Chamber

The third chamber is the floor of the Sun-Mar "CENTREX 1000 Family" which forms the evaporation chamber from where excess liquids may be evaporated. You will frequently see liquid in this area, which is waiting to be evaporated.

In electric and AC/DC units, air is pulled through intake holes at the rear of the unit; over the evaporating chamber, and up the 2" (50mm) vent stack which exits from the front of the composting unit when AC power is being used.

When AC power is unavailable, natural draft caused by the chimney effect of the 4" (100mm) vent stack draws air into the unit and up the 4" (100mm) vent stack.

In the AC mode, the evaporation process is further assisted by a thermostatically controlled heating element in a separate sealed compartment under the evaporating chamber. This heater is on when there is liquid in the evaporating chamber, and mostly off when the chamber is dry. The heating system maintains warmth in the evaporating chamber, and the indirect warmth assists the composting process, without the compost drying out. A safety drain exits from the side

of the composter which drains off any excess liquid to a cess pool, recycling bed, or other approved facility.

## Winter Use

Because "Sun-Mar" units are largely made of fiberglass and high grade stainless steel, freezing temperatures will not damage the composting unit. Composting action decreases as the temperature drops, so for extended use, the toilet should be kept constantly at or above 55-60 degrees F (15 -16C). All exposed vent stacks should be insulated to minimize the condensation in the pipe and avoid ice blockages. Drain pipe should be insulated or, in extreme temperatures, heat tape used to prevent ice blockages.

In extreme temperatures, an additional source of heat will also be required.

If the compost is frozen in the drum, the unit may be used periodically as a "holding tank", until the compost warms up and the microbes emerge from dormancy. Space should be made in the drum to accommodate winter use. The drum should NOT be rotated when the compost is frozen.

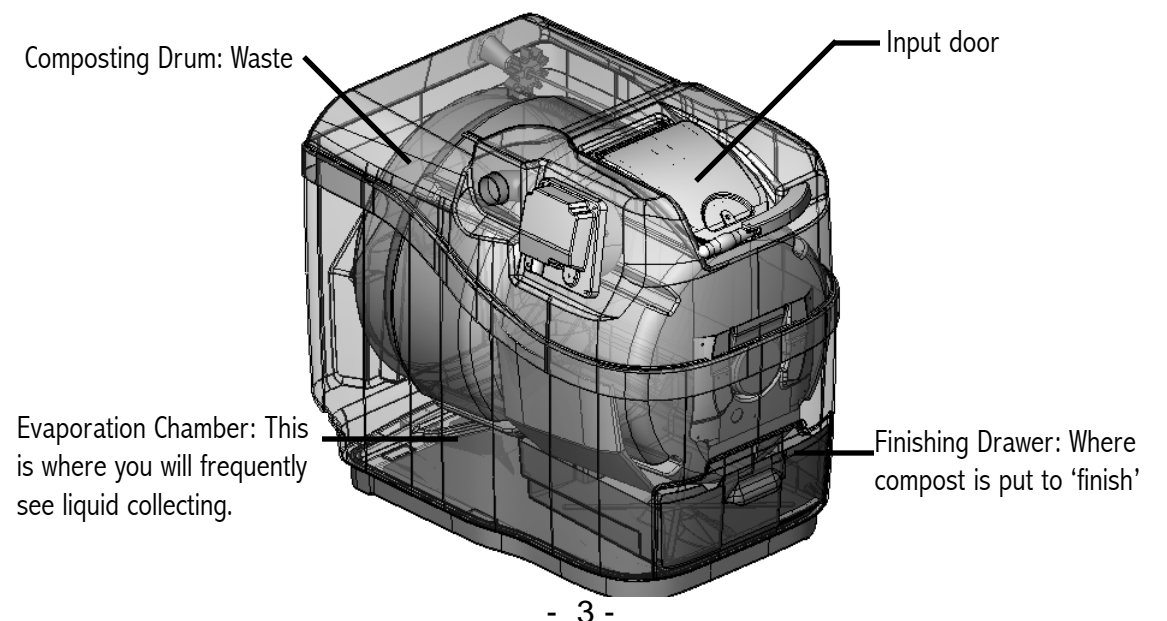

## EXPLOSION DRAWING OF COMPOSTING UNIT

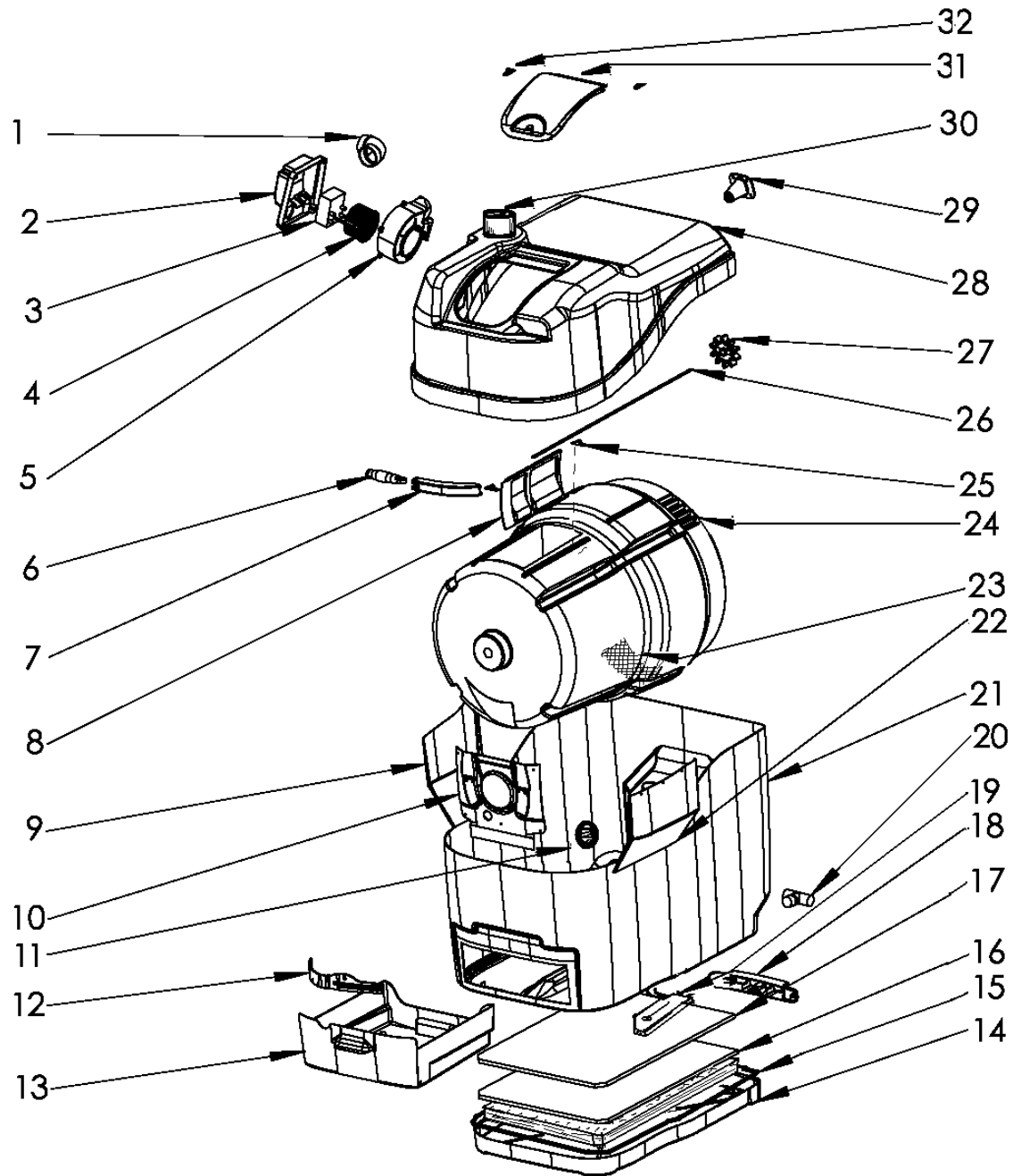

## ACCESSORY ITEMS FOR COMPOSTING

SUN-MAR has developed a number of composting accessory items over the years in response to frequent requests from users. These items may serve to improve composting speeds under some circumstances.

Name	Description	Container	Price*
<b>"Compost Quick"</b>	Solution containing a mixture of enzymes designed to facilitate bacterial activity. Also useful as a cleaner.	16 oz. (454 gm) spray bottle	\$15.50*
<b>"Microbe Mix"</b>	Special selected dried bacteria to decompose waste also includes dried enzymes.	16 oz, (454 gm) Jar	\$16.00*
<b>"Compost Sure Blue"</b>	Bulking material containing 100% chopped hemp stalk to provide moisture retention, porosity, and free air space within the compost.	30 litre (7.9USG) /bag	\$15.00*
<p><i>*Price does not include freight</i>  <i>* Prices subject to change. Please call for current prices before ordering</i></p>			

### Note:

*If the peat moss you are using is powdery and fine, it will result in poor porosity and an excessively wet, oxygen deficient compost. You should change or modify your bulking material. This situation is most likely to happen with central units which are exposed to a lot of flushing liquid. Modify by adding wood shavings, or use "Compost Sure" for optimum results.*

Symptom	Cause	Remedial Action	Prevention
<b>Drum Will Not Turn</b>	Set screw securing handle to shaft has broken	Drill out set screw and replace, or get handle replacement kit (instructions included).	Not a common repair.
	Steel pin securing gear wheel to shaft has broken	Have your serial number ready and call Sun-Mar for a replacement Small Gear Kit.	Keep composting drum from becoming overloaded. This puts undue strain on the nylon gear.
	Drum fallen from bearings.	Have your serial number ready. If the drum has fallen, contact Sun-Mar immediately. We will make sure your problem is fixed quickly.	
	Drum too full	See Section on "Compost Troubleshooting- Drum Too Full"	Drum should never be more than 1/2-2/3 full.
<b>Drum Door Not Opening/Closing Properly</b> <i>(Compost will drop into the finishing drawer even when the drum is not being rotated backwards to extract compost).</i>	Hinges Stuck	Drum Door Hinges have compost caked on them. Clean with wire brush. If this is not effective, use a blunt object (like a nail file) to insert in the hinge slots. This will push the obstruction away so the door swings freely.	
<b>Waste Not Exiting Waste Pipe or Gas Bubbles at Toilet</b>	Waste pipe blocked	<ol style="list-style-type: none"> <li>1. Ensure piping installation remains as per "Installation Instructions" (See earlier section), and modify if necessary.</li> <li>2. Follow "Periodic Check Up" recommendations and options.</li> <li>3. If still blocked, install clear-out port as per "Instructions" (See earlier section) and clear with snake.</li> </ol>	

## CENTREX 1000 Family PART NUMBERS & DESCRIPTIONS

#	PART	DESCRIPTION	#	PART	DESCRIPTION
1	PP-PIPEF-0232XX	2" (50mm)90 Degree Pipe	17	PM-ALUMS-0742XX	Aluminum Sheet (Electric & AC/DC)
2	PP-FAN_0722DX	Fan Door Plastic	18	AO-ELECB-0001AX	Electric Box (Electric & AC/DC)
3	PO-FAN&m-0129XX	Fan Motor	19	AO-THERA-0001AX	Thermostat Assembly(Electric & AC/DC)
4	PO-FANBL-0131BX	Fan Blower Wheel	20	AP-DRAIO-0306XX	Drain Assembly
5	AO-SHAFA-0851XX	SS Shaft Kit	21	PF-TANKE-0747AX	Centrex 1000 Tank
6	PP-HANDS-0843XX	Handle Swivel	22	PP-DEF_R-0758XX	Right Deflector
7	PP-HANDB-0843BX	Handle Block	23	AM-DRUMS-0329XX	Drum Screen
8	AO-DRUMO-2004XX	Plastic Drum Door	24	PP-DRUM0-0749XX	Centrex 1000 Drum
9	PP-DEF_L-0757XX	Left Deflector	25	PP-HINGE-0249BX	Drum Door Hinge
10	PP-GASKO-0188BX	Rubber U Channel	26	AO-SHAFA-0851XX	SS Shaft Kit
11	AP-DRAIO-0306XX	Drain Assembly	27	AO-SMALL-0440XX	Nylon Drive Gear
12	AO-DRUML-0469BX	Drum Locker	28	PF-TPOPC1-0762DX	Centrex 1000 Top
13	PP-DRAWO-0752PX	Centrex 1000 Drawer	28	PF-TOPC1-0762EX	Centrex 1000 NE Top
14	PF-HEATE-0747CX	Centrex 1000 Heater Tray	28	PF-TOPC1-0762FX	Centrex 1000 AC/DC Top
15	PP-GASKO-0188BX	Rubber U Channel	29	PP-SHAHFH-0001XX	Shaft Holder
16	AO-HEATE-0320XX	Heating Element(Electric & AC/DC) C9284-2	30	PP-INLEP-0207CX	Centrex Waste Inlet
			31	AO-ACCEP-0481BX	Access Port
			32		Access Port Hinge

Wiring Diagram

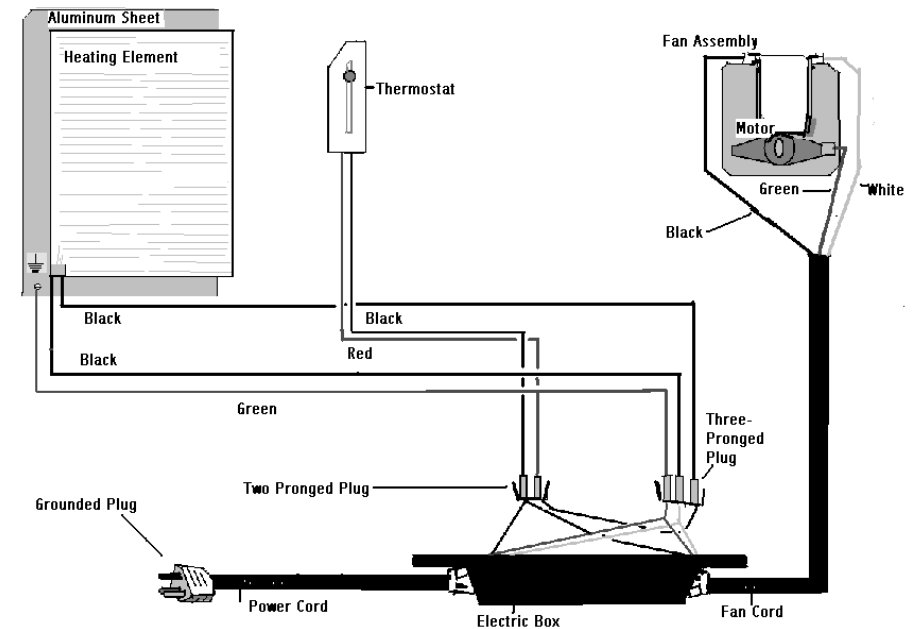

Chapter 1  
**Inspection**

*This chapter describes how to inspect your new CENTREX 1000 prior to installation for damage and make sure you have received all of the parts.*

<b>Inspecting the unit for damage</b>	<p><b>i) If there is any visible damage to the carton-</b>  the contents of carton MUST be inspected before signing bill of lading. Damaged units should be refused. Call Sun-Mar immediately.</p> <p><b>ii) Before signing the shipping papers and dismissing the driver.-</b>  ensure that the carton contents have been inspected.</p> <p><b>iii) If the shipper has left-</b>  Report the damage immediately to the transport company and call Sun-Mar.</p> <p><b>iv) Soon after delivery, remove the CENTREX 1000 carefully from the carton-</b>  If there is hidden damage, or for any service questions, contact Sun-Mar to determine the best course of action.</p>
<b>Check Carton Contents and Familiarize Yourself with the CENTREX 1000</b>	<p>Check that the carton contains the vent stack (pipe, fittings, roof flashing and diffuser); “Compost Sure”, rake, drain hose and fittings, etc. Notify Sun-Mar if you are missing anything.</p> <p>i) Turn the drum handle clockwise to rotate the Bio-Drum for mixing and aeration. (The drum rotates counter-clockwise and the drum door closes). <b>This is how you will rotate the drum.</b></p> <p>ii) Lift and remove the access door and rotate the drum until the drum opening is opposite the access door for adding “Compost Sure Blue”. <b>This is how you will add “Compost Sure Blue”peat moss mixture to the drum.</b></p> <p>iii) Pull the drum stopper on the right side of the unit and turn the drum handle counter-clockwise to simulate extraction of compost into the finishing drawer. (The Bio-Drum rotates clockwise and the output drum door remains open).</p> <p>iv) Plug the unit’s electrical cord into a standard three-prong electrical outlet, and feel the air movement from the vent outlet at the top left of the unit to ensure the vent system is working properly.</p> <p>v) Pull out the compost finishing drawer at the bottom right of the unit, where the compost drops for finishing.</p> <p>vi) After the unit has been plugged in for ten minutes, place a hand on the floor of the evaporating chamber (underneath where the drawer was) to check if it is warm to the touch, and that the heater is working properly.</p> <p>vii) Affix the “WARNING/CLEANING” sticker to the underside of the toilet seat cover, and check that another is on the access port of the composting unit.</p>

Symptom	Cause	Remedial Action	Prevention
<b>Heating System Not Working (Electric &amp; AC/DC)</b>	Test to determine whether failure has occurred	Pull drawer out and put your hand in the evaporation chamber (Not in the liquid). If there is no warmth rising from the floor of the unit, your heating system is not working. It is most commonly the thermostat that has failed. If you notice a lack of evaporation, but there is still warmth in the heating chamber, see “Liquid Buildup” for solutions.	A ground fault interrupter circuit is recommended to protect your CENTREX 1000 from power surges that could cause your heating system to malfunction.
	Thermostat Failure	Have your serial number ready and call Sun-Mar for a replacement. (Detailed instructions are included with the replacement part) If the insulation behind the thermostat access cover is moist or discolored, or heating does not work after the new thermostat has been connected, then the heating element has failed.	Your thermostat and fan are the two constantly moving parts on the unit, and so are the most likely to fail. Both are fairly easy to replace.
	Heating Element Failure	Have your serial number ready and call Sun-Mar for a replacement. (Detailed instructions are included with the replacement part) Please note: Because this part is not easy to replace, and because there is far less chance that you will need this part than a thermostat; we recommend trying to replace the thermostat first.	DO NOT use a pressure hose around the base of the unit.
<b>Liquid in Finishing Drawer</b>	Drum Screen Clogged	Rotate the drum until the drum screen is visible through the access door and scrub vigorously with a wire brush.	
	Unit tilted to right side	Use a 1/4” to 1/2”(6-12mm) wedge piece under the right side of the unit to drain liquid more easily towards the left side overflow drain of the unit.	
	Condensation running down vent stack	Liquid will be clear or yellowish in appearance. Make sure all vent pipe exposed to the outdoor is well insulated and there are no horizontal runs. If the problem persists, call Sun-Mar for a Condensation Deflector, which will channel the liquid into the evaporation chamber.	
<b>Drum Will Not Stay Vertical</b>	Drum Locker Broken	Have serial number ready and call Sun-Mar for a replacement part.	When returning the drum to top dead center position, do not bang against drum locker with excessive force. Remember to pull out the drum locker button before rotating the drum backwards.

Symptom	Cause	Remedial Action	Prevention
<b>Liquid Buildup/ Lack of Evaporation</b>	Increased usage	The amount of liquid varies substantially between installations. The overflow drain needs to be installed on all CENTREX 1000 with low-flush toilets.	Install the overflow drain.
	Failure of heating system (Electric & AC/DC)	Check "heating not working"	
	Mineral salts may have accumulated in the evaporation chamber over a few years, reducing evaporation rates.	To get rid of these, fill the evaporation chamber with very hot water and 1/3 bottle of "Compost Quick" enzyme liquid. Leave overnight. Drain all Liquid through the overflow drain by tipping the unit to the left (make sure overflow is hooked up first)	Rake evaporating chamber vigorously at spring startups for cottage use, and once every other month for residential use.
<b>Overflowing Liquid From Drawer Opening</b>	Overflow drain not hooked up Unit tipped forward or to the right	Connect overflow safety drain (See also increased usage above) Check and ensure that the unit is level or tilting slightly towards the left by placing a 1/4" - 1/2" (6-12mm) shim piece under the right side of the unit.	
	Drains Blocked	<ol style="list-style-type: none"> <li>1. Rake peat mix away from left two corners of CENTREX 1000. These are the "buildup" areas. Use 'hook' end of rake to pull debris from under drain baffles. If drains are still clogged, proceed to step 3.</li> <li>2. Check drain line for kinks, blockages or upward bends. Remove and flush if blockages present, unkink if bent and ensure that the drain pipe is sloping downward. If your drain pipe is in order, proceed to step 3.</li> <li>3. Use a wire to poke peat moss out of the drain assembly at the back. You will notice if this is clogged because you will see a brown spot through the opaque assembly. (Only peat would make it through the drum screen). If there is no peat clog, or the problems continue, backwash the unit quickly with a hose by applying the nozzle to one of the drain assemblies and turning it on and off very quickly. If the bottom of the unit is full of liquid, you may wish to remove some prior to back-washing. A shop-vac works well.</li> </ol>	<ol style="list-style-type: none"> <li>1. A clogged drain is not very likely to happen if you rake your evaporating chamber 1-2 times a season (cottage use) and 3-4 year times for continuous use.</li> <li>2. Use premium 1" (25mm) hose for the drain line. A good hose will be less likely to kink. Use elbows or fittings around bends to prevent kinks.</li> <li>3. Use Compost Sure Blue as your bulking material.</li> <li>4. Make sure evaporation tray is installed properly underneath the drum screen, with the lip pointing towards the drawer and the lowest end pointing towards the drains (to the left)</li> </ol>

Chapter 2  
**Installation**  
**ROUGH IN DIMENSIONS**

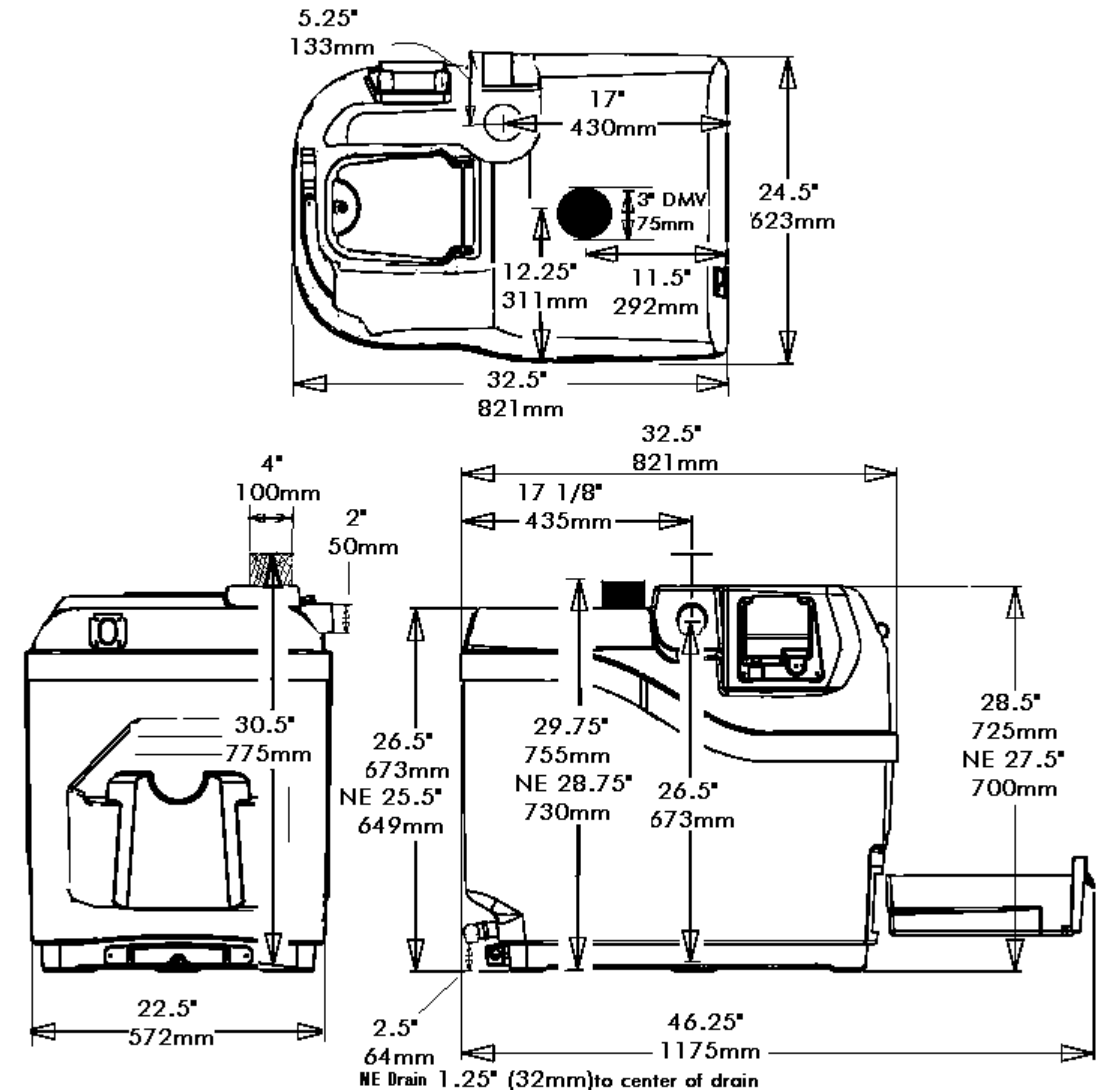

<b>Included In Your Kit</b>	1- Owners Manual	1- 1 1/2" (38mm)Roof Flashing (Electric & AC/DC)
	1- Warranty Card	1- 4" (100mm)Roof Flashing (NE & AC/DC)
	1- Evaporation Tray	6- 2" x 30" (50760mm)PVC Pipe (Electric & AC/DC)
	1- 8' 4" (254cm)Drain Pipe	1- Compost Sure Blue
	1- Rake	1- 4" Diffusor (100mm)(Electric & AC/DC)
	1- 3" (76mm)Centrex Inlet	1- 6" (150mm) Diffusor (NE & AC/DC)
	5- 4" x30" (100x 700mm)PVC Pipe (NE & AC/DC)	1- Centrex Hardware Kit
	1- Centrex NE Hardware Kit (NE & AC/DC)	

- Installing the "1 Pint" Low Flush Toilet**
1. Make sure the center of the floor flange is at least 11 inches (280mm) from the back wall.
  2. When installing a new floor flange, make certain that the toilet mounting bolts align properly with Sealand Traveler toilet mounting pattern.
  3. Secure flange to floor using flat head screws through counter-sunk holes in flange. Insert bolts into slotted holes in flange (Fig. A)
  4. If toilet is being installed in a shower stall, apply a 1/4"(6mm) thick by 3/4"(19mm) wide bead of glazing compound around the circumference of the floor flange (Fig B).
  5. Position floor seal by pressing the floor bolts up through the holes in the seal.
  6. Set toilet in place with bolts protruding up through mounting holes in base (Fig C).
  7. Install washers and hex nuts provided with toilet. Tighten nuts down equally with standard 7/17" (12mm) open end wrench. Remove excess Glazing compound from around base.
  8. Connect water supply line to water valve (1/2" or 13mm MPT) inlet using appropriate fittings (Fig D)
  9. Turn on water supply and flush toilet to test for leaks.
  10. Attach pedestal and pedal covers to toilet base. See instructions below.

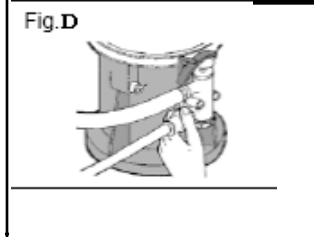
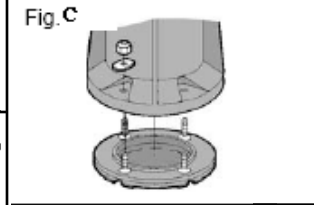
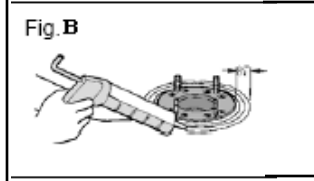
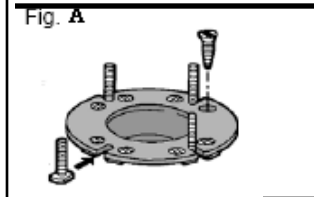
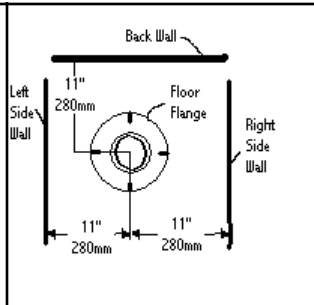

**PEDESTAL AND PEDAL COVER INSTALLATION**

ALL TRAVELER TOILETS AND TRAVELER LITE MODEL 111:

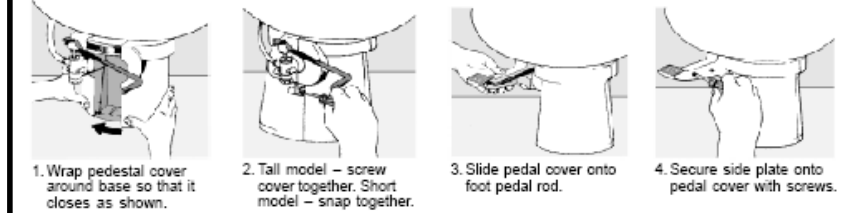

1. Wrap pedestal cover around base so that it closes as shown.
2. Tall model – screw cover together. Short model – snap together.
3. Slide pedal cover onto foot pedal rod.
4. Secure side plate onto pedal cover with screws.

Symptom	Cause	Remedial Action	Prevention
<b>Occasional Urine Odor Outside</b>	1. Vent stack not installed even with peak of roof.	1. Check that the vent is installed 2-3 (60-90 cm)feet above the peak of the roof. If not, extend the vent. Guide wires may be necessary.	Downdraft is dependent on wind direction, as well as natural obstructions, etc. Initially, install the vent 2-3 feet (60-90 cm) above the peak of the roof. If symptoms occur, add lime or a filter box.
	2. If vent stack is installed above roofline, natural obstructions, such as tall trees, being located in a valley or close to a hill may be causing down-draft.	2. Add lime to the evaporation chamber - as much as you think necessary. You will have to rake more often if you do this. You can also add lime to the compost if desired, but no more than 1/2 cup (125ml) per week as it may upset the PH balance in larger amounts. 3. Sun-Mar has a filter box available which will filter the ammonia out of the vented air in a downdraft situation. Call Sun-Mar for details.	
	Compost is anaerobic	Begin following: "Compost Troubleshooting" suggestions.	Follow "Ongoing Maintenance" and use proper bulking material.
<b>Strong Sewage Odor Present when drum turns Fan Noisy</b>	Fan damaged in shipping, or bearings are beginning to wear if it is rattling.	1. If it is rattling, it may need to be cleaned or the bearings are worn and the fan needs to be replaced. 2. A hum is the normal sound the fan will make. If you are in a very quiet setting it will be more noticeable. If this is the case, consider purchasing a fan speed control so that the fan may be turned down when the noise bothers you. 3. If it is a vibration noise, you may need to tie down the top of the stack with guide wires and bracket the pipe that runs up the side of the structure.	Clean the fan with a small brush and/or compressed air nozzle once every 2-3 years in cottage use, or once a year residentially. To do this, remove the fan assembly by taking off the snap cap covers and unscrewing the screws which hold it in. The entire assembly will then simply slide out. This will prevent wear and lengthen the life of your fan.
	Fan vibrations resonating in vent pipe (12 Volt Fan)	Use pipe clamps to secure vent pipe or install fan with rubberized couplings to help absorb vibrations.	
<b>Fan Not Working</b>	Debris in fan or Mechanical Failure.	Have your serial number ready and call Sun-Mar.	The fan is a continuously moving part which will eventually have to be changed. Do Not turn on and off daily.

Chapter 5  
**MECHANICAL TROUBLE SHOOTING**

Most problems are prevented through proper maintenance and the use of proper bulking materials in the composting unit. If you do have a problem, the Trouble Shooting section will help you solve it. If you still have further questions, contact technical service at Sun-Mar for advice at 888-341-0782

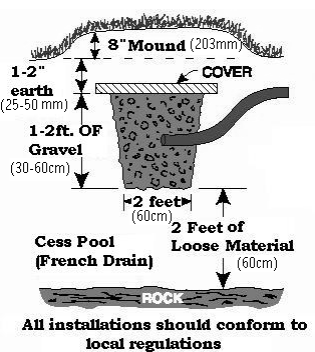
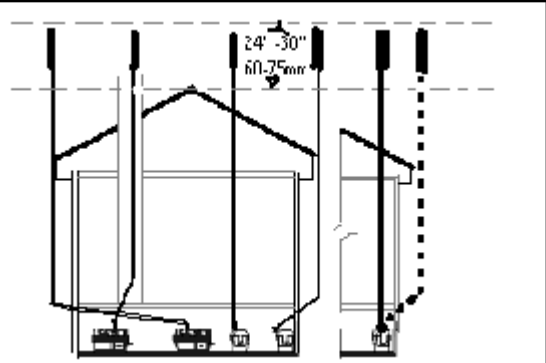
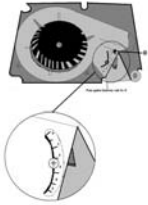

Symptom	Cause	Remedial Action	Prevention
<b>Urine Odor Around Unit</b>	Horizontal runs or downward slopes on pipe are causing condensation to block pipe.	Re-install the vent so there are no longer any low points where condensation can collect. If re-installation is not possible, drill a small hole in the bottom of the low point (preferable outdoors) to allow condensation to drain. (Note: watch for icing in winter at this hole.)	Install wall brackets on vent pipe to prevent settling. DO NOT install horizontal runs as liquid will collect and block ventilation, causing odor.
	Fan has failed (110 volt)	Have your serial number ready and call Sun-Mar for a replacement. Instructions are included with the replacement fan.	The fan is a constantly moving part and has a finite service life.
	Fan has failed (12 volt)	Remove and replace fan. Fan should be on when installed. When it is turned off it forms an obstruction in the vent.	
	Device other than Sun-Mar diffuser is installed on top of the vent stack	Wind turbines or vent caps may be discouraging air movement. If so, replace with a Sun-Mar diffuser.	Wind turbines or vent caps should not be installed on or, instead of a Sun-Mar diffuser.
	Room where unit is located is airtight.	1. Hold a lighter up to the air intake holes on the back of the unit. Air should be drawn into the holes. If air is not easily pulled in, check venting for too many bends or horizontal lengths and/or provide more ventilation to the room. 2. Install fresh air intakes on any competing appliances.	Install your CENTREX 1000 in an area with plenty of ventilation and watch for competing appliances such as bathroom fans and wood stoves.
	2" (50mm) Vent stack has too many bends and/or horizontal lengths.	1. Re-install the vent stack to reduce the number of bends/eliminate horizontal lengths. 2. If the vent stack cannot be further straightened, remove the fan assembly and reduce the amount of recirculating air by covering up the area between the fan exhaust and the 90 degree vent intake elbow with duct tape.	Install the vent with minimal bends (total bends should equal no more than 360 degrees) and NO horizontal or downward slopes.

<b>Installation Considerations for the waste pipe</b>	<p>When installing the waste piping from the toilet to the composting unit, the following considerations should be born in mind:-</p> <ul style="list-style-type: none"> <li>i) The piping should be either 45 degrees or more to the vertical (if composting unit is directly below toilet), or at a 2-3 degree angle (1/8"-1/4" or 3-13mm drop per foot maximum) so that the waste travels with the liquid.</li> <li>ii) Piping should not slope upwards at any point.</li> <li>iii) Connections should be snug so that waste is not encouraged to "hang up" where pipe meets connector.</li> <li>iv) It is recommended that the waste pipe not be longer than 15 feet (460cm) without installing a clear out port(a Y fitting with screw on end cap) near the toilet to provide easy access should it ever be required.</li> <li>v) Use a soft sealant, such as silicone for the connection of the waste piping to the composting unit so that the composting unit can be moved for servicing or other reasons should this ever be required.</li> <li>vi) Insulate piping if unit is to be used during the winter.</li> </ul> <p>For heavy winter use, the composting unit will need to be kept warm by enclosing it, insulating the enclosure, and providing some heat source. The enclosure must not be airtight since the unit must be able to draw air in.</p>
<b>The 3" Waste Inlet</b>	<p>The 3"(75mm) waste inlet (supplied with kit) should be installed where the waste pipe feeds into the composting unit. This assembly will allow the waste to flow into the Bio-Drum without interfering with the drums' function. If more room is needed in your installation, you can substitute this assembly by constructing your own 3" (75mm) waste assembly from the examples shown below.</p> <p>This assembly can be constructed by using a 3 (75mm)inch coupling or elbow (as shown below) and a piece of 3 inch(75mm) pipe. Glue the pipe into the end of the coupling or elbow that will sit on the composting unit waste inlet opening. Cut this pipe so that only 1/2"(13mm) protrudes from the coupling or elbow. This pipe will fit in the waste inlet hole and should end just above the opening in the drum, without interfering with drum movement.</p> <div style="text-align: center;"> </div>
<b>Drain Installation</b>	<p>The drains must be connected for all applications. The 1" (25mm) Safety drains at the back of the "Centrex 1000", exit to both the right and left. To connect one of the drains, (whichever is convenient), remove the plug, attach the 1"(25mm) hose (included) and secure with a hose clamp. Ensure there are no kinks or upward bends in the drain hose.</p>

<b>Handling Effluent</b>	<p>The following are possible options to take care of the liquid:</p> <ul style="list-style-type: none"> <li>- Use a container which is emptied periodically (water jug or small barrel). This ensures a closed loop system.</li> <li>- Feed into a lined pit filled with gravel and sand. Such a recycling bed also ensures a closed loop system.</li> <li>- Feed into a small cesspit or "french drain".</li> <li>-Plumb into an existing septic or holding tank line.</li> </ul> <p>Installation should be in accordance with applicable local regulations.</p>	 <p><b>All installations should conform to local regulations</b></p>
<b>Vent Piping Location</b>	<p>Piping can be installed up the inside wall; through the wall at a slight angle and up the outside wall. The choice depends on ease of installation, visibility, and (especially if the toilet is to be used consistently through a cold winter), the necessity of insulating all exposed vent pipe.</p>	 <p><i>The vent on the right is a 4" (100mm) non-electric vent. All others show possible 2" (50mm) Centrex 1000 (electric) vent configurations.</i></p>
<b>Adjusting the fan gate(Electric and AC/DC)</b>	<p>If you believe that there may be a downdraft outside of the building, it may be a good idea to remove your fan assembly prior to installation and set the fan gate to '0' to prevent urine odor in the bathroom. The fan gate is factory set to '3', which recirculates air within the unit. If there is a downdraft you may get blow back into the room where the unit is installed. When setting the fan gate to '0', you may lose some evaporation so it is also wise to hook up the emergency drain.</p>	
<b>Vent Piping Installation</b>	<p>Piping and fittings are of standard 2" (50mm)PVC thin wall tubing(central vacuum) and/or 4" (100mm) PVC thin wall pipe. Additional pipe or fittings can be purchased from a building supply dealer. If you cannot find them near your location, you can substitute schedule 40 pipe and use a rubber coupling to join this pipe to the unit.</p> <p>i) Minimize the number of sharp angles in the 2" (50mm) vent as each reduces vent efficiency. The 4" (100mm) vent should be installed as near to vertical as possible. It is recommended if it is necessary to have angles in the 4" (100mm) vent pipe that 45 degree angles are used whenever possible. On the 4" (100mm) DC stack, bends should be limited to 2 - 45 degree angles. will necessitate the installation of a 12 volt fan.</p>	

Symptom	Cause	Remedial Action	Prevention
<b>Flies Present</b>	<ul style="list-style-type: none"> <li>-compost too dry</li> <li>-compost anaerobic</li> <li>-kitchen/garden waste added</li> <li>-foreign material added</li> </ul>	<ol style="list-style-type: none"> <li>To get rid of flies, you can use any pesticide that is used on your garden. Pesticides used for garden use are not anti-bacterial so are safe to use on your compost. If you prefer not to use a pesticide in your compost, the unit should be cleaned out completely and washed with soapy water to kill any remaining eggs. Once the unit is washed, it should be rinsed well to remove all traces of soap before restarting the compost.</li> <li>If using a pesticide to kill the insects, it may be purchased from a local garden center or hardware store.</li> <li>If using a liquid, sprinkle about 1/2 cup (125ml) of the mixture directly over the compost. Using a spray bottle, apply throughout the entire toilet (finishing drawer, evaporating chamber, drum, out side of drum) until the fly population is eliminated. Open a window or door to ventilate the room while applying and keep children and pets away from the area for a few hours after application. Repeat if you see another fly after the initial application.</li> </ol> <p><b>IMPORTANT:</b> Application of a pesticide in a Sun-Mar composter is not a health concern because all Sun-Mar units are vented.</p>	<ol style="list-style-type: none"> <li>Keep compost moist. In order to determine a good level of moisture, shine a flashlight into the drum. The compost should have a slight gloss or shine. If it does not, add warm water to it until it reaches this consistency. Fungus gnats tend to be attracted to a dry compost, due to the fungus which begins to form on the surface when it dries out. A good, moist compost will not be attractive to flies.</li> <li>Do not add topsoil from the ground, composted matter, or kitchen scraps to the toilet. Flies may be present in, or attracted to these items.</li> <li>If toilet is installed over an old septic line, make sure that the lines are well sealed. Insects find unused lines attractive.</li> <li>See "Compost Remediation" if the compost smells- anaerobic compost will attract flies and drastically reduce the performance of your composting unit.</li> <li>Use "Compost Sure Blue" or a mixture of peat moss and non-cedar wood shavings.</li> </ol>

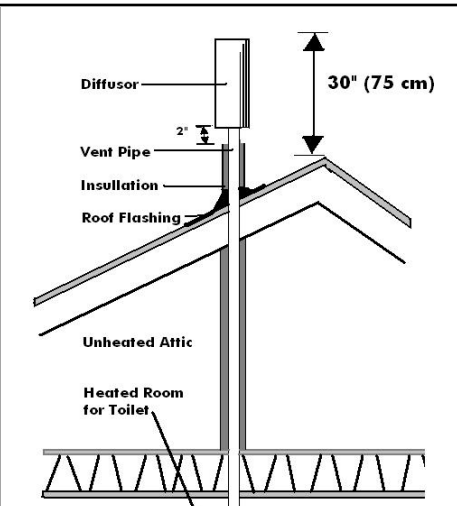
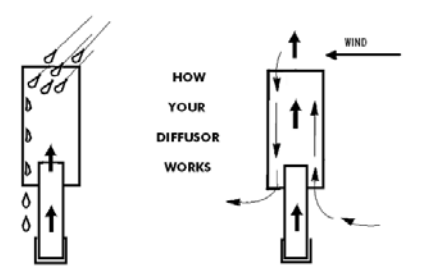
Symptom	Cause	Remedial Action	Prevention
<b>Waste not Breaking Down at all (cont'd)</b>	Antibiotics being used for more than a few weeks on a continuous basis may kill bacteria	Empty drum. Hose out inside of drum. Restart compost according to "Initial System Startups".	When used normally, antibiotics will only slightly slow compost. Add Sun-Mar Microbe Mix and/or Compost Quick during this period to accelerate compost action. Urinating elsewhere during this period will also help minimize the damage to the compost.
<b>Lumps</b> <i>If many large lumps have formed in drum, you will need to remove them or break them up with the rake tool. Follow the prevention column to ensure this does not happen.</i>	Compost Too Dry	Follow instructions for "Compost Too Dry" above. And also add 1/2 gallon (1000ml) of wood shavings.	Follow recommendations for checking and adding moisture in "PERIODIC CHECKUP".
	Over-Rotation of Drum	Follow "ONGOING TOILET MAINTENANCE", and also add 1/2 gallon (1000ml) of wood shavings.	Drum should be turned three times a week, 4-6 rotations each time; once before departure for weekend use.
	Peat moss used as bulking material with no wood shavings.	Begin using Compost Sure Blue or 100% non-antibacterial wood shavings as bulking material.	Use proper bulking material.
<b>Drum Too Full</b> <i>Note: The drum is too full when it is over 2/3 full, and the door is not closing properly.</i>	Compost not emptied into finishing drawer in a timely fashion.	1. Remove compost until drum is only half full or less. Rotate compost thoroughly to aerate, and add compost accelerants (Compost Quick and Microbe Mix) if available.  2. If you need to dump more than one drawer of compost, and you do not already have a suitable backyard compost heap, you may try an open-slatted wooden crate (such as the kind used to pack age fruits and vegetables). Layer compost with bulking material and leave crate outside for around 2 months to finish composting.	When drum is 1/2 full, remove some compost to the finishing drawer by rotating the drum backwards, to avoid surprise over-filling of drum. Do NOT let drum get above 2/3 full. (The drum is 2/3 full when the level of the compost reaches 2-3" (50-75mm) below where the drum door hangs) This will lead to lack of aeration, and anaerobic compost, and the inconvenience of having to remove more than one drawer.
	Kitchen/Garden Waste added		Do Not add kitchen or garden waste.

<b>Vent Piping Installation (Cont'd)</b>	<ul style="list-style-type: none"> <li>ii) Do not lead the 2" (50mm) vent pipe downward or horizontally at any point. This may lead to the vent pipe being blocked by condensation which would cause a urine smell in your bathroom.</li> <li>iii) All connectors in the vent pipe should be sealed. <b>Use silicone for the connection of the vent stack to the toilet in case the composting unit has to be moved or you have to access the fan.</b> PVC cement may be used in the rest of the stack installation if desired.</li> <li>iv) All exposed vent pipe should be insulated with the foam insulation. This is especially important for winter or residential use.</li> <li>v) The Sun-Mar 12 Volt fan is fitted inside a 11" (280mm) length of 4" (100mm) vent pipe for easy installation, should it be needed. It is installed by either cutting out a section of the vent immediately above the composting unit, or by raising the vent stack off of the composting unit and inserting the fan section. The fan can be used with a solar panel and 12 volt battery, or by purchasing a 12 volt adapter from your local hardware store and simply plugging it into the wall.</li> </ul>
<b>Leading the vent through the roof</b>	<p>As shown in the installation, the vent stack should end about 30" (60-90 cm) above the peak of the roof so that it is less subject to downdraft. Where the piping is taken through the roof, the roof flashing provided should be used to seal the installation. Insert the vent into the bell of the roof flashing and slide the roof flashing down until it lays evenly on the roof. Slip the upper edge or the roof flashing flange under the shingles. Outline the flashing on the roof. Raise the roof flashing and apply silicone sealant or roofing tar inside the outline. Slide the flashing back into place and firmly press onto the sealant. The flashing is properly placed when the top part of the roof flashing flange is tucked under the shingles and the lower portion is sealed on top of the shingles so that water sheds easily. Secure the flashing with corrosion resistant nails at each corner and along sides. Any exposed nails should be sealed with silicone caulking.</p> 
<b>The Diffusor</b>	 <p>The diffusor provided with the unit is a simple device to be installed at the top of the vent stack with the larger pipe protruding above the smaller. To install, simply glue the diffusor on the topmost section of vent pipe. The diffusor design encourages updraft, and discourages wind and weather from going down the vent stack. Unlike wind turbines, diffusors are less likely to freeze up in winter, and are more effective in calm weather.</p>
<b>Electrical Considerations (Electric and AC/DC)</b>	<p>A ground fault interrupter (GFI) circuit is recommended to protect your composting unit from electrical problems. This may be installed directly on the wall socket or at the circuit breaker.</p> 

**12 Volt Fan Installation (AC/DC)**

Every Sun-Mar AC/DC model comes with a 12 Volt Fan for installation in the 4" (100mm) stack. Its installation is required in the following situations:

- If you are installing both 2" and 4" vent stacks (prevents downdraft from the 2" or 50mm vent)
- If you are in an area where you are subject to downdraft
- If you are using the unit residentially
- If you need to install the vent stack with bends

We include it because many AC/DC owners do install both vent stacks. It may also be installed later if you wish simply by cutting a section out of your vent and replacing it with the fan.

To install the fan initially, pick a spot on the stack that you can reach easily. In order to get the best evaporative performance from the fan, install it near the toilet if possible (remember, the fan will still not be enough to evaporate all liquids in a non-electric or DC only environment). Once you have placed it where you wish, use silicone caulking, or rubberized couplings, to make the installation airtight. Do not use ABS glue at this area as you may need to change the fan at a later date.

The 12 Volt Fan may be powered with a battery that is connected to a generator, solar panel, or other alternative energy system. For use in AC, purchase a 12 Volt to AC Adapter from any electrical store and snip off the female end - wire the positive wire to the red wire on the fan, and the negative wire to the blue wire on the fan. Tie them off with small wire connectors, and plug your AC Adapter into the wall.

The 12 Volt Fan should be continuously running if used, as if it is not running it will act as a block in the vent stack.

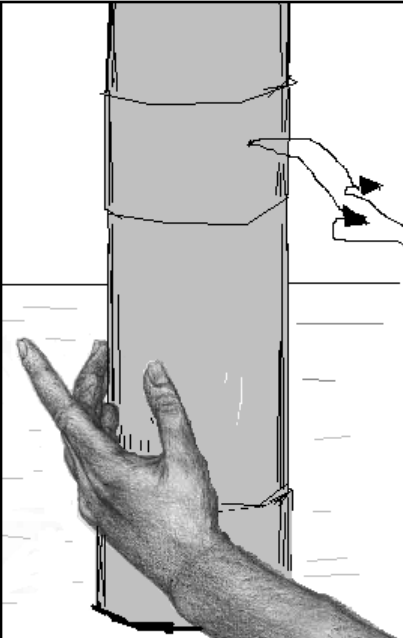

Symptom	Cause	Remedial Action	Prevention
<b>Compost Too Wet</b>  <i>Your compost is too wet when there are standing pools of liquid. Compost will smell of sewage and is anaerobic</i>	Compost porosity is poor. Too much peat moss has been used as a bulking material. This is compacting, preventing liquid from draining through, and leaving no free air space for oxygen.	For an immediate improvement in porosity add about 1/2 gallon (1 liter) of wood shavings, of any kind (except cedar) to the drum.  On an ongoing basis, change bulking material to Compost Sure Blue or a 100% wood shavings.	Use Sun-Mar Compost Sure or 25% peat moss, 75% wood shavings as a bulking material.
	Drum screen clogged	Rotate drum so that the drum screen is visible through access door. Scrub screen with wire brush. Make sure your overflow drain is hooked up beforehand if there is a large liquid buildup in the drum.	
<b>Compost Too Dry</b>  <i>Compost is too dry when compost looks flat and brown rather than rich and black.</i>	Moisture not being added periodically or before departure on cottage units.	Add 1/2 to 1 gallon (1-2 liters) of warm water to compost in order to bring it up to appropriate moisture level.	Follow section on moisture in "PERIODIC CHECKUP".
	Toilet not used for urination.	Peat moss retains moisture. 40-60% moisture content is ideal for aerobic microbes to thrive.	Use toilet for urination.
	Insufficient bulking material or not enough peat moss. Insufficient Microbes	Add Sun-Mar Microbe Mix or unsterilized black earth from a garden center.	Add correct bulking material.
<b>Waste not Breaking Down at all</b>  <i>If this is the case, the drum will fill up quickly</i>	Room Temperature under 60F(15-16C)	Install heat source to increase temperature. Temperature should be kept above 55-60F(15-16C) constantly if toilet will be used on an ongoing basis.	Be sure to add Microbe Mix packet at startup.  Install unit in warm area. The warmer the area, the better your compost will be! If evening temperatures fall below the prescribed temperatures on a residential unit, consider installing a heat source on a timer for evenings.
	Bleach or other anti-bacterial chemicals	Empty drum. Hose out inside of drum. Restart compost according to "Initial System Startups".	Never add bleach or cleaning chemicals.

## Chapter 4 Compost Troubleshooting

*This chapter will deal with problem that may arise with your compost, what is required to make your compost healthy and how to correct problems if they arise.*

### Requirements of an Aerobic Compost

In a Sun-Mar, a good compost is predominantly aerobic, which means that oxygen is available for aerobic bacteria throughout the Bio-drum. Aerobic bacteria consume waste quickly and odorlessly to produce carbon dioxide and water vapor and leave behind a small fraction of the original waste volume in the form of basic minerals. The end compost is a mix of valuable minerals and bulking material that has not decomposed.

To work effectively to break down waste, aerobic bacteria need oxygen, moisture, available carbon (from the bulking material), and warmth.

In a Sun-Mar, oxygen is provided by the tumbling of the drum and the bulking material leaving free air space within the compost. Moisture is provided by the waste, and is made available to aerobic bacteria by the moisture retention properties of the bulking material. If the compost is too dry, add warm water.

In summary, to keep the compost aerobic, it is important to rotate the drum, add bulking material, and keep the compost moist.

### Oxygen

Lack of oxygen becomes a problem where:

- Too much moisture eliminates the free air space,
- A lack of bulking material limits free air space,
- Aerobic bacteria use up oxygen in the compost.

Lack of oxygen causes the compost to become increasingly anaerobic, which means that aerobic bacteria are displaced by anaerobic bacteria. Anaerobic bacteria work slowly and produce undesirable ammonia, hydrogen sulfide, and methane. Consequently, the maintenance of 'free air' space by periodically rotating the drum and adding the right bulking material is very important in Sun-Mar units. Excessive rotation is not helpful and can harm the compost by disturbing the bacteria too much.

### Moisture

If there is too much moisture, and the compost is approaching saturation, oxygen is pushed out and anaerobic activity predominates. On the other hand, if there is too little moisture, aerobic activity slows. For this reason, it is important to maintain adequate moisture levels (40-60% moisture content is ideal). Generally, if you shine a flashlight in after mixing, there should be a slight sheen of moisture on your compost.

### Warmth

Too little warmth will cause aerobic activity to slow. Below 55-60 degrees F.(15-16C), microbes will go dormant and composting will stop. Composting speeds increase dramatically with temperature.

### Characteristics of a Bad Compost

If your compost is over 8 weeks old and it exhibits one or more of the following characteristics, then an operating change is indicated.

- ✓ Extraction required too often (under 4 weeks)
- ✓ Large Lumps present in compost
- ✓ Compost muddy or clay-like
- ✓ Flies present (this may also be a problem with foreign matter being added to unit; see section on flies)
- ✓ Compost has strong unpleasant smell of sewage when drum is turned.
- ✓ Toilet paper present in finishing drawer

### Troubleshooting

In using this troubleshooting section, you should follow remedial action in the order that they are given, unless you are sure of the problem. You should see improvement in a week, and your compost should be back to normal in 2-3 weeks. If it is not, make sure that "Ongoing Toilet Maintenance" is being followed and check the mechanical troubleshooting section.

## Chapter 3 Start Up and Use

*Although the start up instructions remain the same no matter what your application, different situations will require different actions and this chapter will explain what they are.*

### Initial System Start Up

Begin operation by carrying out the start up procedure described below, and then continue with the "Ongoing Toilet Maintenance" routine. It normally takes six weeks before a compost is properly established. You will know this has happened when:

- **Compost Volume increases more slowly**
- **Compost turns black and becomes loam-like**
- **Toilet paper decomposes within a few days**

	<b>Action</b>	<b>Why?</b>
<b>ADD</b>	3-4 gallons of peat mix (half the 30 liter bag provided) to the drum.	-Provides carbon base and initial mass for compost.
<b>ADD</b>	1/2 Microbe Mix packet at start up, other 1/2 in two weeks	-Adds necessary microbes which will breakdown the compost.
<b>SPRINKLE</b>	About 1/2 gallon(1 liter) of warm water into the drum	-Moistens carbon base
<b>PLUG IN</b>	Fan and heater are operating	-The unit is ready for use
<b>SPRAY</b>	"Compost Quick" enzymes into drum before and after mixing. Coat the evaporation chamber with it before using the unit.	-Speeds start up of compost by acting as a catalyst to assist bacteria. -Prevents possibility of start-up odor in the evaporating chamber.
<b>RAKE</b>	Loose peat mix from the evaporating chamber until the compost is established, which takes approximately 6 weeks.	-Until the compost is active, some peat moss may fall through the screen or drum door into the evaporating chamber
<b>POSITION</b>	Black evaporating tray under drum screen to the left of the drawer, so that the lip is towards the drawer and the lower portion is towards the drains.	Extends the surface area of evaporation chamber

*\* Toilet paper is a good source of carbon and should be added after use.*

### **CAUTION**

1. Do **NOT** add or clean the toilet bowl with chemicals. Chemicals will kill the bacteria. **INSTEAD**, clean the bowl with "Compost Quick", or very hot water and baking soda.
2. Do **NOT** add plastic, glass, metal, cleaning fluids, cigarettes. Add only waste and bulking material.
3. Kitchen or garden waste are **NOT** recommended.

## Annual Start Up (seasonal units only)

Many units are only used regularly throughout the summer. For such seasonal units Sun-Mar recommends that the following start up procedure be followed at the beginning of the season.

Action	Reason for Action
<b>Empty</b> the compost that had been left in the finishing drawer, and use the rake to clean out the evaporation chamber.	- <i>Your fertilizer is ready.</i> - <i>This is a good time to remove peat debris</i>
<b>Remove</b> additional drawers of compost (if there is more than 6 - 8" or 150-200mm in the drum), by releasing the drum lock (white button on right side of unit), and rotating the drum clockwise (the handle turns counter-clockwise) to extract compost into the drawer. (At the beginning of the season, it will all be finished compost) Empty the drawer and repeat extraction cycle until the level in the drum is reduced to about 6"(150mm).	- <i>Frees space in the composting chamber for the new seasons composting.</i>
<b>Add</b> 1/2 gallon (1 liter) of warm water.	- <i>Raises moisture level</i>
<b>As an option for optimal composting,</b> Add SUN-MAR "Microbe Mix" or unsterilized black earth from a garden center. We do not recommend using topsoil as it may contain fly larvae.  SUN-MAR "Compost Quick" enzyme can also be used as a compost accelerant.	- <i>Even though the compost still has microbes in it, you may want to start the year by replenishing your batch of microbes.</i>  - <i>Compost Quick helps to accelerate the action of the microbes.</i>

## Periodic Check Up

Once your unit has been through initial or annual startups, and ongoing maintenance procedures are being followed, Sun-Mar recommends a system of periodic checks be undertaken.

Action	Reason for Action
<b>Rake</b> peat moss debris from the evaporation chamber, making sure to rake from the rear of the chamber, including the back two corners of the unit. Raking should occur on a yearly basis for cottages (best done at annual startups), and a bi-monthly period for continuous users.	- <i>Ensures drains cannot get plugged and evaporation is improved.</i>
<b>Check</b> your compost moisture level on each visit for cottage users and once every two weeks for continuous users. This can be done by shining a light into the Bio-Drum. The compost should have a slight gloss or shine to it. A moisture meter may also be used if so desired. Range should be 4-6, which represents 40% to 60%	- <i>A good compost is between 40% and 60% moisture content.</i> - <i>Prevents lumps, ensures toilet paper breaks down quickly.</i> - <i>Prevents insects</i>
<b>Pour</b> 1 gallon (2 liters) of very hot water down the toilet.	- <i>Ensures waste piping remains free-flowing.</i>
<b>Extract</b> compost when Bio-drum is 1/2 full by releasing the drum lock (white button on right side of unit), and rotating the drum clockwise (the handle turns counter-clockwise) to extract compost into the drawer.	- <i>Frees space in the composting chamber.</i>

## Ongoing Toilet Maintenance

The procedure below is designed to keep the compost:

- **Moist, but not too wet**
- **Well aerated and mixed**
- **Well balanced and aerobic**

Action	Reason for Action
<b>Add</b> 1 cupful (250ml) of Sun-Mar Compost Sure Blue (or 100% non-cedar wood shavings) to the Bio-Drum per person per day of use.	- Maintains the carbon/nitrogen balance - Absorbs liquid - Helps oxygen penetrate for aerobic composting
<b>Turn Handle</b> to rotate the drum 4-6 complete revolutions of the drum, three times a week when in use, or, if used only at weekends, only on departure. DO NOT forget to return the drum opening to a position under the wastepipe.	- Mixes and oxygenates the compost
<b>Unplug</b> the unit if you are leaving for a period of more than a few days. If you are leaving one weekend and coming back the next, you may unplug the unit. Consider installing a timer to shut the unit off after 48 hours to evaporate excess liquid. If you are leaving for a period of more than a few days, and the compost appears dry, add approximately 1/2 gallon (1 liter) of warm water to keep the compost moist.	- unplugging unit will conserve power and keep compost from drying.  - addition of water helps keep the compost moist
<b>Extract</b> some compost into the finishing drawer when the drum is 1/2 full. It is 1/2 full when the compost reaches a level about 4-6 " (100-150mm) below the drum door when the door is open. To empty some compost into the drawer, pull the drum locker button and rotate the handle counter-clockwise (to turn the drum clockwise). Turn at the same speed you would normally do for mixing. If necessary, use the rake to level the compost in the drawer. If there is not enough compost in the drawer, turn the drum backwards (clockwise) again 1 rotation. Leave the compost in the finishing drawer to finish for 3-4 weeks or until you next need to remove compost from the drum. <b>If your unit is used seasonally and is not used heavily, you may not have to remove any compost at all during the season. If so, follow "Annual Startups".</b>	- Moves some compost to the next stage for finishing  - Ensures that the drum does not get too full  - Provides extra time for composting to be completed

\*\*Sealand Toilet users; Removal of the Sealand Water Valve is advised for winter months where the toilet portion may be exposed to freezing temperatures. The plastic housing of the water valve will crack if any moisture is left inside, necessitating the replacement of this part which is NOT covered under your warranty.